



## Interface Control Document

VRDV-1000-xx
SHEET 1 of 9
ICD
Issue No.. B

# VRDV-1000-xx-ICD Digital Video Hard Disc Recorder/Player



VRDV-1000-xx
SHEET 2 of 9
ICD
Issue No.. B

## Interface Control Document

### General Description

This specification applies to the Digital Video Recorder VRDV-1000-xx and its variants. The Digital Video Recorder has been optimised for aircraft operation typical in airborne surveillance applications.

This Display contains:

- Power input filter and Power supply module
- Video processing and control electronics
- Disk transport and head assembly
- Control and front panel assembly

The VRDV is designed for recording edit ready clips directly to its integrated hard drive from any composite video source...while you're flying. Drive technology eliminates the lengthy "capture" and digitisation process in preparing evidential presentations. Clips are instantly accessible by your computer based Non Linear Editing System (NLE) for report preparation and archiving. The output may also be transferred to tape.

- Simple Operation Digital Video Capture System
- Variable Storage options
- Move video Files to Your computer editing Timeline Faster than Real-time
- Works with any composite video source – Record Audio and Video Directly to Built-In Disk Drive - No Formatting Required
- Quick & Easy VCR Style Transport Controls
- Fast Forward / Reverse, Pause and Single Frame Stepping
- Transfers Files Via USB2
- Shock Protected
- Compatible with PC & Mac Non Linear Editing systems (NLE)
- 28V DC Aircraft supply
- Dzus panel mounting

The VRDV-1000-xx offers a direct Digital Video recorder pre-formatted internal hard-disk drive, which enables the system to function as an Hard disk drive (HDD) when connected to a computer or as a stand alone VTR, complete with front-panel controls for record, play, and pause. During recording, Digital video is processed as raw content into a standard file scheme that allows a virtually unlimited number of clips to be appended.

Operating in HDD mode, the digital video recorder provides access to the disks video files in Motion JPEG format that can be imported into most Non Linear Editing systems (NLE) systems. The video content is available instantly and ready for editing. Operators also may use the system for archiving purposes, recording to both tape and HDD simultaneously.

The VRDV-1000-xx is a full turnkey digital video capture system, requiring no additional equipment.

The VRDV-1000-xx is a Dzus rack mounted, self-contained open format DVR that can play and record digital video captured directly from a camera and/or recorder onto a hard disk drive (HDD). The captured video clips are considered "edit-ready" and are compatible with Mac and PC based Non Linear Editors.



VRDV-1000-xx
SHEET 3 of 9
ICD
Issue No.. B

## Interface Control Document

The VRDV-1000 is manufactured in a number of models:

- VRDV-1000-01 40Gbyte drive
- VRDV-1000-02 60Gbyte drive
- VRDV-1000-02 80Gbyte drive

The VRDV-1000 is also available as a portable unit for base operations.

The unit will also allow archiving of clips or the entire disc at the end of the mission.

The VRDV-1000 is a high quality digital video recording and playback device designed for standalone operation. It was designed as a subsystem for applications requiring video conforming to Phase Alternation by Line (PAL) specifications or National Television Standards Committee (NTSC). The unit performs compression and decompression at user-specified ratios as low as 4:1 at full frame rate. The compression method conforms to the Joint Photographic Experts Group (JPEG) standard. The primary design goal was professional image quality. In addition, the system adheres strictly to standards including CCIR-601 and RS-170A (NTSC). When recording, the unit converts an analogue PAL or NTSC video signal to a component digital format, compresses the digital video signal to a JPEG data stream, and sends the compressed video directly to an ATA/IDE (ATA/ATAPI-4) hard disk. Video files are downloadable to a computer via USB port for editing in a non-linear editor or playback with QuickTime video player.

Control of the unit is through front panel push buttons.

When playing back, the unit retrieves the compressed video data from the IDE hard disk, decodes the JPEG data into digital component video, and converts the digital video to an analogue PAL or NTSC video signal. Composite video and Y/C input processing, decoder, and encoder are included in the unit.

The units pixel resolution is full bandwidth CCIR-601; 720 X 576 in PAL and 720 X 486 in NTSC. Sampling is maintained at 4:2:2.

### USB OPERATION

The USB connection is used to view recorded video using the QuickTime player on a computer. The files must be recorded using the FAT32 Disk format and the QT file format. The drivers are included in Windows 2000 and Windows XP for the connection. The drive should show up as an external drive when the USB cable is connected and the DVR is powered On, unless the unit is in Record. The DVR will not allow USB access when recording since all data on the drive could be damaged / deleted by doing so. Connecting the USB cable during Play will Stop the DVR because the DVR and the USB cannot access the drive simultaneously.

The files containing video will be named RQAAAABB.mov, where the 'AAAA' and 'BB' are hexadecimal numbers. All other files on the drive are not video files, and therefore, are not playable. The FAT32 format limits file size to 2 GB. Long video clips will span file boundaries.

The filenames will indicate sequential files in a clip by incrementing the digits 'BB' from 00 to as many files as are in one clip.

Video requires a fast computer to play smoothly in real time. If your video does not play smoothly, QuickTime Pro has a setting under the Movie tab to Play all frames. This slows the video to the speed of the computer, but shows all of the frames recorded.



VRDV-1000-xx
SHEET 4 of 9
ICD
Issue No.. B

## Interface Control Document

<b>VIDEO INPUT</b>	
Analogue Input:	Composite and optional S-Video (Y/C).
Levels:	1.0Vp-p, 75 ohms
Standards:	625/50 (PAL) or 525/60 (NTSC)
<b>VIDEO OUTPUT</b>	
Analogue Output:	Composite and optional S-Video (Y/C).
Horizontal Resolution:	550 TV lines (at 5:1 compression)
Levels:	1.0Vp-p, 75 ohms
Standards:	625/50 (PAL) or 525/60 (NTSC)
Connections:	multi-pin for component
<b>VIDEO INPUT DECODER</b>	
Format:	Digital 4:2:2 YCrCb 50 fields per second PAL 60 fields per second NTSC
Digital Colour Space:	YUV
Sampling:	13.5 MHz
Pixel Resolution:	720 x 576 pixels (625/50) 720 x 486 pixels (525/60)
S/N Ratio:	50 dB
Bandwidth:	7 MHz (-3 dB)
Differential Gain:	2%
Differential Phase:	2 deg.
ADC Differential Linearity:	+/- 0.7 LSB
ADC Integral Linearity:	+/- 1.0 LSB
<b>VIDEO OUTPUT ENCODER</b>	
Digital Colour Space:	Digital 4:2:2 YCrCb
Analogue Bandwidth:	Y: 6.75 MHz C: 1.3 MHz
Composite:	4.5 MHz
DAC Resolution:	10 bits x 3
S/N Ratio:	60 dB
<b>VIDEO COMPRESSION</b>	
Codec:	Zoran
Method:	JPEG (Joint Photographic Experts Group)
Compression Ratio:	Variable from 20:1 to 4:1.
<b>MEMORY</b>	
Multi-port Frame Buffer:	32 MB DRAM
<b>AUDIO SPECIFICATIONS</b>	
Resolution:	16 bits
Sampling Rate, FS:	48 KHz
Channels:	2 Line in , 2 line out
Dynamic Range:	90 dB
Total Harmonic Distortion:	-80 dB
Crosstalk:	-80 dB
Input Voltage:	1 VRMS nominal
Input Impedance:	35k ohms
Input Programmable Gain Span:	22.5 dB
Full Scale Output Voltage:	1.0 VRMS
Output Impedance:	10k ohms
Output Attenuation Range:	80 dB



VRDV-1000-xx
SHEET 5 of 9
ICD
Issue No.. B

## Interface Control Document

### Connectors

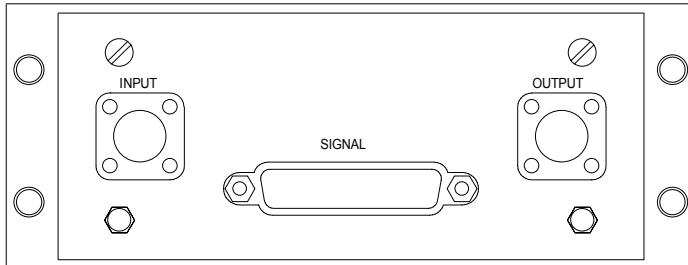

#### 1. Signal Connector DB25 Plug with jacking screws

##### Pin assignment

1	28V Return (0V)
2	Data
3	Data
4	Data
5	Data
6	Composite Video In (Lopped with input BNC)
7	Composite Video In screen
8	Composite Video Out (Looped with Output BNC)
9	Composite Video Out screen
10	
11	
12	
13	
14	
15	
16	
17	
18	Audio In screen
19	Audio In (L)
20	Audio In (R)
21	Audio Out (screen)
22	Audio Out (L)
23	Audio Out (R)
24	
25	28V DC Power in

#### 2. Video In/Out

- BNC
- Inner (Video signal)
- Outer (Video Screen)

## Interface Control Document

### Controls

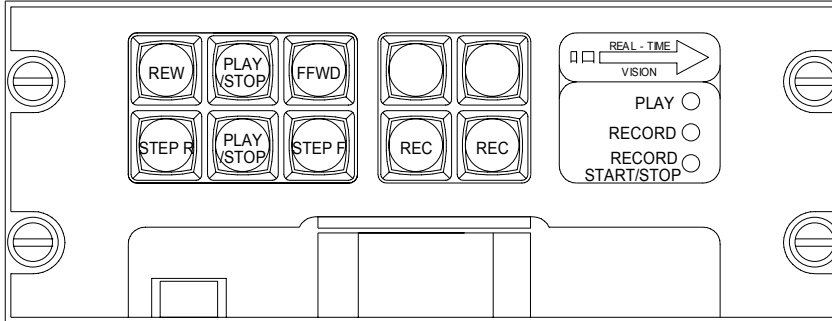

REV ◀◀	PLAY/STOP ▶	FWD ▶▶			
STEP R ◀	PLAY/STOP ▶	STEP F ▶		REC ●	REC ●

PUSHBUTTON OPERATION			
Function	Req. State	Keys	Notes
Start Record	Any but Record	● + ●	
Stop Record	Record	▶ + ● + ●	Hold Play/Stop and tap Record
Change to Pass-Thru	Play or Stop	◀ + ▶	Simultaneous
Play forward – 1x	Stop	▶	
Pause	Play	▶	
Step Fwd 1 frame	Play or Stop	▶	
Step Rev 1 frame	Play or Stop	◀	
Seek start next clip	Play or Stop	▶▶	
Seek to end	Play or Stop	▶▶	Hold for ½ second
Seek start previous clip	Play or Stop	◀◀	
Seek to beginning	Play or Stop	◀◀	Hold for ½ second
Scan Fwd – 5x	Play ≠ 5x	▶ + ▶▶	Simultaneous
Scan Fwd – 30x	Play = 5x	▶ + ▶▶	Simultaneous
Scan Rev – 5x	Play ≠ -5x	◀ + ◀◀	Simultaneous
Scan Rev – 30x	Play = -5x	◀ + ◀◀	Simultaneous
Clear Disk	Any but Record	◀◀ + ▶▶ + ● + ● ◀◀ + ▶▶ + ● + ●	Keys pushed and held in order, released (LEDs “Record” and “Play” flash quickly), and repeated once.



## Interface Control Document

### LED Indication

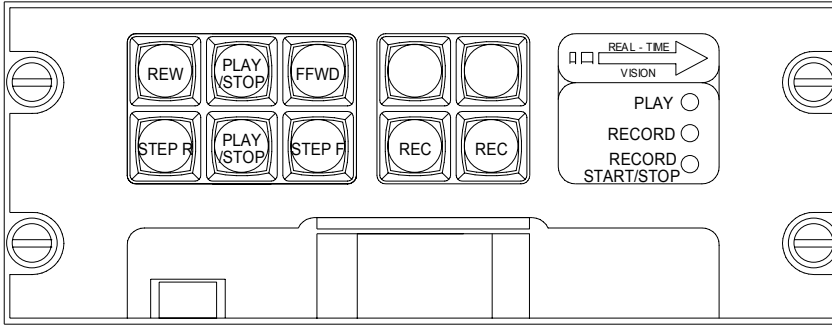

MODE	ACTION	LED	LED DISPLAY
Pass-Thru	Pause	RECORD	On - 0.1 Sec. per Sec. - Single short blink per second.
Pass-Thru	Record	RECORD	LED On.
Playback	Stop	PLAY	On - 0.1 Sec. per Sec. - Single short blink per second.
Playback	Play (1:1)	PLAY	LED On.
Playback	Forward - non 1:1	PLAY	LED high in a pattern short, short, long, short
Playback	Reverse - non 1:1	PLAY	LED high in a pattern short, long, short
Confirm Video Delete		RECORD & PLAY	Alternate short blinks.
Pass-Thru	At Record Start	REC START/STOP	On for 3 seconds.
Pass-Thru	At Record Stop	REC START/STOP	On for (3x) 0.3 second pulses separated by 1 second



VRDV-1000-xx
SHEET 8 of 9
ICD
Issue No.. B

## Interface Control Document

### Handling Precautions

Handling of the Recorder should be in compliance with Real-Time Vision's handling principles.

- 1) Since the recording disc is a precision assembly and is easily damaged by excessive shock. The internal disk is soft mounted to isolate routine shocks. Excessive shock can cause the disc to fail.
- 2) Be sure to turn off power supply when inserting or disconnecting the input connectors.
- 3) Wipe off water or fluid droplets immediately. Long contact with water or other fluids may cause discoloration or spots.
- 4) When the surface is soiled, wipe it with absorbent cotton or other soft cloth.
- 5) Since the recorder contains precision bearings, it may break or distort if dropped or bumped on hard surface.
- 6) Since CMOS LSI is used in this module, take adequate static electricity precautions and ensure correct human earth bonding when handling.
- 7) Do not open nor modify the Assembly.
- 8) At the insertion or removal of the Power and Signal Interface Connector, ensure that the sockets are free from debris and be sure not to damage the Interface pins
- 9) After installation of the unit into a mounted position, do not twist nor bend the unit even momentary. When designing a suitable mounting, it should be taken into consideration that no bending/twisting forces are applied to the unit from outside. Otherwise the tape transport module may be damaged.

#### **LIMITATION OF LIABILITY**

The manufacturer's liability for damages to customer or others resulting from the use of any product supplied hereunder shall in no event exceed the purchase price of said product.

#### **IMPORTANT USAGE NOTE**

This equipment is for use by developers and integrators, the manufacturer accepts no liability for damage or injury caused by the use of this product. It is the responsibility of the developer, integrators or other user of this product to:

- Ensure that all necessary and appropriate safety measures are taken.
- Obtain suitable regulatory approvals as may be required.
- Check power settings to all component parts before connection.

#### **Disclaimer**

Real-Time Vision reserves the right to make changes to this document and the product which it describes without notice. In addition, Real-Time vision. shall not be liable for technical or editorial errors or omissions made herein; nor for incidental or consequential damages resulting from the furnishing, performance, and use of this product.

This product shall not be used for or in connection with equipment that requires an extremely high level of reliability, such as life critical systems, nuclear power control equipment and medical or other life support equipment. Real-Time Vision. takes no responsibility for damage caused by improper use of this product which does not meet the conditions for use specified in this specification sheet.



© COPYRIGHT 2003  
 THIS DRAWING IS THE PROPERTY OF REAL-TIME-VISION.  
 AND IS NOT TO BE USED, REPRODUCED OR COMMUNICATED IN ANYWAY WITHOUT PRIOR WRITTEN CONSENT OF THE COMPANY.

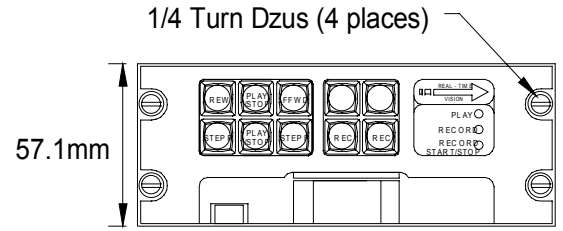
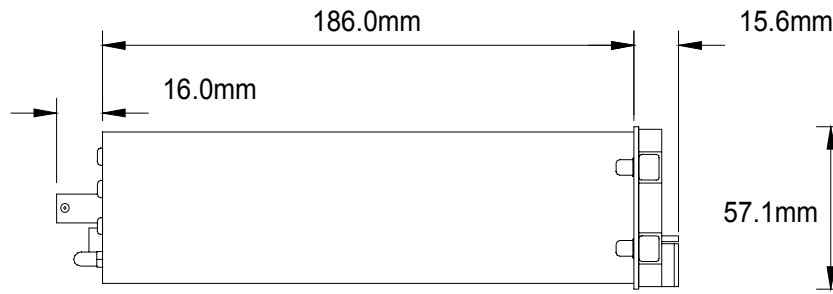
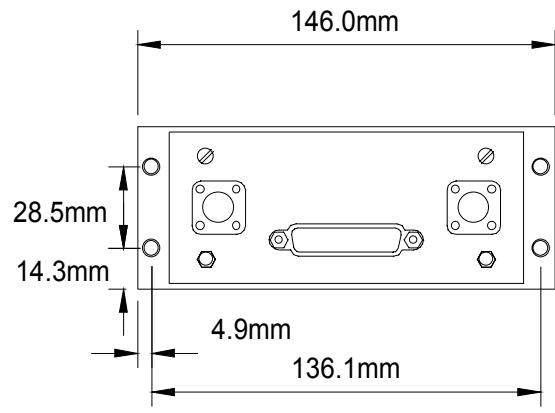

THIRD ANGLE PROJECTION  
 DO NOT SCALE

MATERIAL:-					
FINISH:-					
AJM		B	5th April 2005	AJM	
CJS		A	15th June 2003	AJM	
DRAWN	ECO No.	ISS.	ACTIONED	APPROVED	CHECKED

DIMENSIONS :-		
SCALE NTS		
GENERAL TOLERANCES		
TWO DECIMAL PLACES ± 0.025 ONE DECIMAL PLACE ± 0.125 NO. DECIMAL PLACE ± 0.4 ANGLES ± 1'		
PROJECT :-		ENGLAND UNITED KINGDOM
TITLE:- Video Recorder Digital video		
DRG No. VRDV / 1000 / xx		REV B
SHT 1 of 1 A3		